

Redline



Implements

Tel: 0800 872 2767

www.jinma.co.za/implements.html

Model: FM-5



Important:

Read these instructions before installing and using this implement.

**Finishing
Mover**

CONTENTS

CONTENTS	1
PRODUCT SPECIFICATIONS	2
SAFETY INSTRUCTIONS	3
OPERATION	6
SERVICE AND MAINTENANCE	9
PARTS LIST	12

PRODUCT SPECIFICATIONS

Product NO.

FINISHING MOWER MODELS

FM-150 PTO driven rear or side discharge models with ~ 3 high strength cutting blades.
~ 4 independent height adjustable castor wheels.

FM-180 PTO driven rear or side discharge models with ~ 3 high strength cutting blades
~ 4 independent height adjustable castor wheels.

Implement Specifications

MODELS	FM-150	FM-180
Tractor HP	20-35hp	30-55hp
3-point linkage	Cat-1	Cat-1
Length	1380mm	1700mm
Width	1580mm	1850mm
Height	820mm	880mm
Weight	188kg	210kg
Cutting Width	1490mm	1790mm
Cutting Height	30-80mm	30-80mm
Number of Blades	3	3
Discharge	Rear or Side	Rear or Side
PTO	540r/min	540r/min

The Finishing mowers are PTO powered with two available model sizes, in category I three point linkages, from 5 to 6 foot for tractors up to hp.

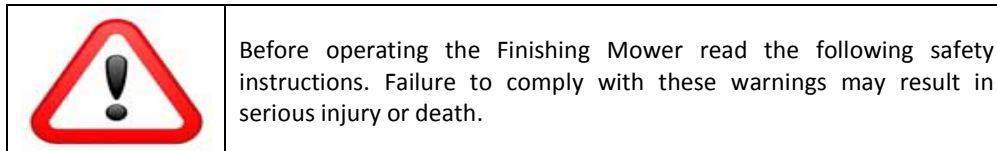

CONGRAGULATIONS! On the purchase of your new Redline Finishing Mower. This information is to assist you in preparing, Operating and maintaining your mower. Please read and understand the information completely before operating your mower, paying special attention to all the safety details. Keep this manual handy for a ready reference.

1.1 Safety First

YOU are responsible for the SAFE operation and maintenance of your Finishing mower. YOU must ensure that you and anyone else, who is going to operate, maintain or around the Finishing mower is familiar with the operating and maintenance procedures and related SAFETY information contained in this manual. This manual will take you step-by-step through your working day and alert you to all good safety practices that should be adhered to while operating the Finishing mower.

Remember, YOU are the key to safety. Good safety practices not only protect you but also the people around you. Make these practices a working part of your safety program. Be certain that EVERYONE is aware of the operating

and maintenance procedures, and follows all the safety precautions. Most accidents can be prevented. Do not risk injury of death by ignoring good safety practices.

SAFETY INSTRUCTIONS

- 1 Finishing mower owners must give operating instructions to operators or employees before allowing them to operate the machine.
- 2 The most important safety feature on this equipment is a SAFE operator. It is the operator's responsibility to read and understand ALL Safety and Operating instructions in the manual and to follow these. All accidents can be avoided.
- 3 A person who has not read and understood all operating and safety instructions is not qualified to operate the machine. An untrained operator jeopardizes himself and bystanders to possible serious injury or death.
- 4 Do not modify the equipment in any way. Unauthorized modification may weaken the function and/or safety and could affect the life of the equipment.
- 5 Think SAFETY! Work SAFETY!

1.2 General Safety

1. Read the operator's Manual and all safety signs carefully before operating, maintaining, adjusting or removing the Finishing mower.
2. Do not allow passengers to ride on the Finishing mower.
3. Operate only at safe distance from bystanders. Clear the area of people, especially small children, before starting.
4. Stop PTO before dismounting tractor.
5. Keep feet and hands from under finishing mower at all times.
6. Keep all shields in place. If shield removal becomes necessary for repairs, replace the shield prior to use.
7. Do not stay between the tractor and the Finishing Mower.
8. Do not approach the Finishing mower until all motion has stopped.
9. All rotary blades have the ability to discharge objects at high speeds, which could result in serious injury to bystanders or passers-by, use with extreme caution.
10. Place all controls in neutral, stop tractor engine, set park brake, remove ignition key and wait for all moving parts to stop before servicing, adjusting, repairing, attaching or removing.
11. Review safety related items annually with all personnel who will operate or maintain the Finishing mower.
12. Do not operate machine if you feel unwell or physically unfit, in which case you should stop working.
13. This machine was designed with safety very much in mind. However, there is no real substitute for caution and attention in preventing accidents. Once an accident has happened, it is too late to think about what you should have done.
14. Use a tractor equipped with a Roll Over Protective Structure (ROPS). Always wear your seat belt. Serious injury or even death could result from falling off the tractor – particularly during a turnover when the operator could be pinned under the ROPS or the tractor.
15. Never exceed the limits of a piece of machinery. Or its ability to do a job, or do so safely, is in question – DON'T TRY IT.
16. Clear working area of stones, branches or hidden obstacles that might be hooked or snagged, causing injury or damage.

1.3 Operating Safety

1. Read and understand the Operator's Manual and all safety signs before operating, servicing, adjusting, repairing or removing.

SAFETY INSTRUCTIONS

2. Do not allow riders.
3. Install and secure all guards and shields before starting or operating.
4. Keep hands, feet, hair and clothing away from moving parts.
5. Place all controls in neutral, stop tractor engine, set park brake, remove ignition key and wait for all moving parts to stop before servicing, adjusting, repairing, attaching or removing.
6. Place all tractor and machine controls in neutral before starting.
7. Never start or operate machine unless sitting on the tractor seat.
8. Clear the area of bystanders, especially small children, before starting.
9. Stay away from PTO shaft and machine when engaging PTO. Keep others away.
10. Use warning lights on tractor when transporting.
11. Do not put hands or feet under machine while tractor engine or machine is running
12. Do not operate Finishing mower in the raised position.
13. Objects can be thrown out from under machine with sufficient force to severely injure people. Stay away from machine when it is running. Keep others away.
14. Always know what you are cutting. Never operate Finishing mower in an area that has hidden obstacles. Remove sticks, stones, wire or other objects from working area before starting.
15. Review safety instructions with all operators annually.

1.4 Storage Safety

1. Store the machine in an area from human activity.
2. Do not permit children to play on or around the stored machine.
3. Store the machine in a dry, level area.
4. Clean grease and oil as required and protect it from the elements.

1.5 Maintenance Safety

1. Good maintenance is your responsibility. Poor maintenance is an invitation to trouble.
2. Follow good shop practices.
3. Keep service area clean and dry.
4. Be sure electrical outlets and tools are properly grounded.
5. Use adequate light for the job at hand.
6. Make sure there is plenty of ventilation. Never operate the engine in a closed building. The exhaust fumes may cause asphyxiation.
7. Before working on this machine, shut off the engine, set the brakes, and remove the ignition key.
8. Never work under equipment unless it is secured by a mechanical stand.
9. Use personal protection devices such as eye, hand and hearing protectors, when performing any service or maintenance work. Use heavy gloves when handling blades.
10. Only use genuine parts for service and maintenance.
11. A fire extinguisher and first aid kit should be kept readily accessible while performing maintenance on this equipment.

12. Periodically tighten all bolts, nuts and screws and check that all pins are properly installed to ensure unit is in a safe condition.
13. When completing a maintenance or service function, make sure all safety shields and devices are installed before placing machine in service.

SAFETY INSTRUCTIONS

1.6 Safety & Model Decal

The position of safety decals are shown in the illustrations below. Good safety requires that you familiarize yourself with the various safety signs, and increase your **SAFETY AWARENESS**.

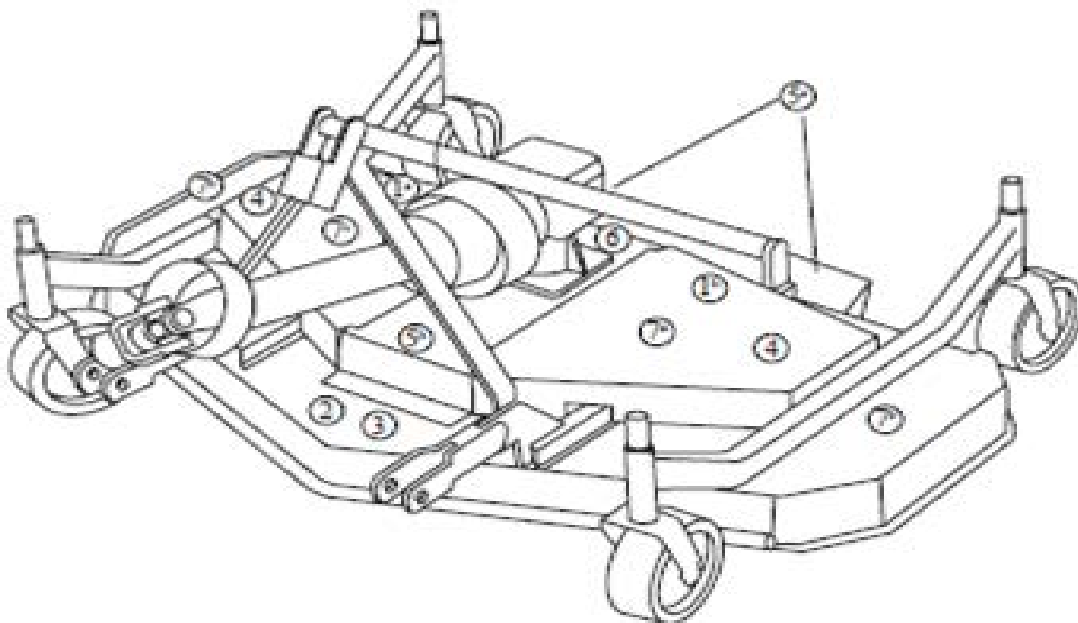

SAFETY INSTRUCTIONS

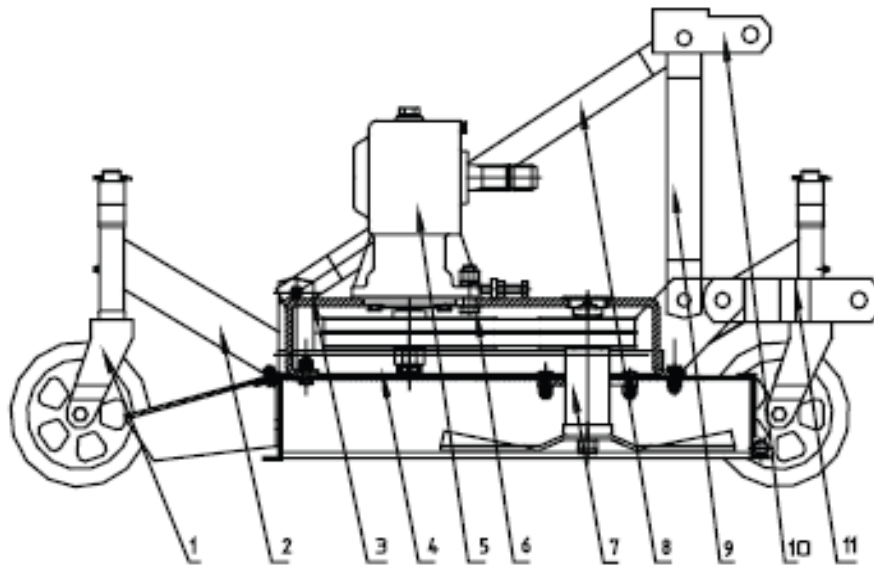

1. Wheel assembly	2. Wheel bracket	3. Gearbox seat	4. Deck
5. Gearbox	6. Belt pulley	7. Blade spindle	8. Brace
9. A Frame	10. Top link Bracket	11. Bottom link Bracket	

PTO Shaft

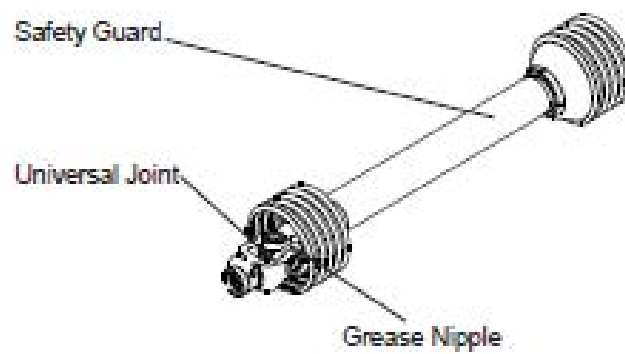

OPERATION

2.1 Checking Before Operating

Before operating the machine, the following areas should be checked off:

1. Before starting up the machine, check and lubricate all grease points – cutting deck, wheels & PTO shaft.
2. Use only an agricultural tractor of horsepower within limits of the machine specified.
3. Check that the machine is properly attached to the tractor. Be sure retainers are used on the mounting pins.
4. Be sure extra weights are mounted on the front of the tractor.
5. Check the oil level in the gearbox. Add as required.
6. Check that the tractor PTO shaft turns freely and that the machine driving shaft can telescope easily.
7. Check the blade. Be sure they are not damaged or broken and swing freely in their mount. Repair or replace as required.
8. Check and tighten the blade Bolts.
9. Check for entangled material in all rotating parts. Remove this material.
10. Install and secure all guards, doors and covers before starting.

2.2 Running – In: First 10 hours

Although there are no operational restrictions on the Finishing mower when used for the first time, it is recommended that the following mechanical items be checked:

A. After operating for ½ hour or after completing 2 acres:

1. Check and tighten all nuts, bolts and other fasteners.
2. Check that the blades are in good condition and swing freely.
3. Check the oil level in the gearbox. Add as required.
4. Check that the machine driving shaft shield turns freely.
5. Lubricate all grease points.

B. After operating for 5 hours and 10 hours:

1. Repeat items 1 to 5 of Section A.
2. Then go to the regular service schedule as defined in CHAPTER 3.2.1.

2.3 Equipment Matching

To insure the safe and reliable operation of the Finishing mower, it is necessary to use a tractor with the correct specifications. Use the following list as a guide in selecting a tractor to use on the machine.

1. Horsepower:
The power requirements range from 15hp for light cutting in level terrain up to 55 hp in heavy cutting in rough terrain. Use a tractor appropriate for your conditions and implement model. See product specifications page 2
2. Front End Weights:
It is recommended that tractor be equipped with front-end weights to provide extra stability. This is particularly important if using front-wheel assist tractor.
3. Three Point Linkage.
The Finishing mower is equipped with a category 1, three point hitch. Be sure the tractor three point hitch is in the proper configuration.

Adjust the linkage sway chains to provide minimal sideways movement.

OPERATION

4. PTO Shaft must have a 1 3/8 inch 6 spline 540 RPM PTO shaft to fit the driving shaft supplied with the machine. Do not use shaft adapters or operate at any other speed.

It is not recommended that a tractor with variable speed PTO's be used on the Finishing mower. Operating at speeds faster than 540 RPM will overload the cutting components and lead to early failures.

2.4 Attaching / Removing

The Finishing mower should always be located on a level, dry area that is free of debris and other foreign objects.

The machine coupling is equipped with 3 pins so that the machine can be coupled with all tractors with universal coupling. Use a solid or soft top-link to allow the mower to "float" behind the tractor.

When attaching the machine to the tractor, follow this procedure:

1. Lower the hydraulic linkage arms using the control.

Note:

It may be necessary to add weight to the three points hitch to lower the lift arms.

2. Back the tractor at low speed towards the Finishing mower and adjust the lower links to the proper level.
3. Stop tractor, set park brake, remove ignition key and wait for all moving parts to stop before dismounting.
4. Connect the tractor's lower links with Finishing mower's left and right lower suspension bracket and put pins in. Connect the top-link with Finishing mower's top-link bracket and put pin in.
5. Attach the machine PTO shaft to the tractor's PTO by retracting the locking pin, Slide the universal joint over the shaft and push on the universal joint until the lock pin clicks into position. Pull on the universal joint to be sure it is locked in position.
6. Make sure that the PTO shaft telescopes easily and that the shield rotates freely.
7. Use the 3 point hitch to raise the machine from the ground before moving the machine.
8. Reverse the above procedure when removing the machine from the tractor.

2.5 Field Operation

Lower the implement into its "float" operating mode to allow the machine and the hitch to move up and down.

1. Move the machine into the field and align the machine with the working area.
2. Adjusting the height:

There are 4 sets of adjusting spacers on the wheel fork, which allow the cutting height range of 30mm-80mm by adjusting spacers to achieve the height.
3. Starting machine:
 - c. Run the engine at low idle.
 - b. Slowly engage the PTO clutch to start the machine.
 - c. Slowly bring the engine to the rated PTO speed. Never exceed rated speed.
 - d. Lower the machine to the ground and proceed down the field.
4. Stopping machine:
 - d. Slowly decrease engine speed to low idle.
 - b. Disengage PTO clutch slowly.

OPERATION

5. Ground speed:

Travel speed can vary between (5 and 13 kph) depending on the grass and terrain conditions. It is the responsibility of the operator to note the condition of the job being done and set the speed to obtain a quality job and maintain control of the machine.

The speed can be increased on smooth open easy cutter.

Decrease speed if you are producing a ragged cut or leaving patches uncut.

When transporting the machine, review and follow these instructions:

1. Be sure that the machine is securely attached to the tractor and all retainer pins are installed.
2. Be sure you have installed extra weights on the front of the tractor.
3. Be sure you are in compliance with all applicable lighting and making regulations when transporting.
4. Be sure your machine can be seen clearly by overtaking and oncoming traffic.
5. Do not allow riders.
6. Always use hazard flashers on the tractor when transporting.

SERVICE AND MAINTENANCE

3.1 Service

3.1.1 FLUIDS AND LUBRICANTS

1. Grease:
Use multi-purpose lithium based grease.
2. Gear Box Oil.
Use SAE 90 Gear oil.
3. Storing Lubricants:
Your machine can operate at top efficiency only if clean lubricants are used. Use clean containers to handle all lubricants. Store them in an area protected from dust, moisture and other contaminants.

3.1.2 GREASING

1. Use a hand-held grease gun for all greasing.
2. Wipe frame slide clean before greasing.

3.2 Maintenance

The recommended period is based on normal operation conditions. Severe or conditions may require more frequent maintenance.

3.2.1 HOURS OR DAILY MAINTENANCE

- 1 Check and screw all nuts and bolts in connection parts.
- 2 Check the oil in gearbox. Fill up to line if it's necessary.
- 3 Pump grease into each grease nipple three to five times.
- 4 Clean the implement; take away all grass and mud.

3.2.2 SEASON MAINTENANCE

- 1 Check the machine as above for daily maintenance.
- 2 Check the oil in gearbox; replace it if is contaminated.
- 3 Check the bearings of blade spindles for wear and tear. If warn, disassemble, clean and replace them if it is necessary, grease as required.
- 4 Check the distance between bearings and gears. Adjust them if it's necessary.

3.2.3 ANNUAL MAINTENANCE

- 1 Thoroughly clean the mower of mud and grass.
- 2 Drain the gearbox and clean it thoroughly. Fill with new gear oil up to the dedicated oil level.
- 3 Check and clean blade axles. Replace oil seals and grease them.
- 4 Check all blades, replace them if they are warn out or damaged.
- 5 Check/ Repair the side skids; return them to original technical condition. Replace damaged or broken protective devices.
- 6 Remove the drive shaft from the tractor from the machine. Pull the PTO shaft apart. Check and replace any components that are damaged or worn. Install the PTO shaft on the machine. The PTO shaft should telescope easily and the guard turn freely on the shaft.

SERVICE AND MAINTENANCE

	8hrs/Daily			40hrs/Weekly			Annually		
Lubricate PTO Shaft	X			X			X		
Lubricate Caster Wheels	X			x			X		
Lubricate Blade Spindle	x			X			X		
Check Gear Box Oil Level				X			X		
Clean Machine							x		
Lubricate and Clean PTO Shaft Cover							x		

3.2.4 PTO SHAFT MAINTENANCE

The PTO shaft is designed to telescope to allow for dimensional changes as the machine goes through its operating range. A tubular guard encloses the driving components and is designed to remain stationary on a turning shaft when required. The shaft should telescope easily and the guard turn freely on the shaft at all times. Annual disassembly, cleaning and lubrication is recommended to ensure that all components function as Intended. To maintain the shaft, follow this procedure:

1. Remove the shaft from the machine.
2. Pull shaft apart.
3. Use a screwdriver to pry the tabs out of the sleeves on each end. There are 3 tabs per guard.
4. Pull the shaft out of the plastic tubular guard.
5. Use a solvent to clean the male and female portions of the telescoping ends.
6. Apply a light coat of grease to each end.
7. Clean grooves on each end where the tabs are located. Clean each tab also.
8. Apply a light coat of grease to each groove.

9. Insert the shaft into its respective guard and align the slots with the groove
10. Insert the tabs through the slots and seat in the groove.
11. Check that each guard turns freely on the shaft.
12. Assemble the shaft.
13. Check that the shaft telescopes easily.
14. Replace any components that are damaged or worn.
15. Install the shaft on the machine.

3.2.5 GEARBOX MAINTENANCE

The gearbox used on the Finishing mower will give many years of free-service with minimal maintenance requirements. Maintain the gearbox by following this procedure:

Oil level:

- Remove the level plug from the rear or side of the gearbox.
- Add oil through the filler plug located on top of gearbox until oil comes out of level plug.
- Add through the fill plug if required.
- If gearbox has a dipstick on filler plug, then fill to indicator mark.

SERVICE AND MAINTENANCE

IMPORTANT: Check the level only when the unit is cold and the machine is on level ground.

3.3 STORAGE

After the season's use, the machine should be thoroughly inspected and prepared for storage. Repair or replace any worn or damaged components to prevent any unnecessary down time at the start of next season. To ensure a long, trouble free life, follow the procedure outlined below:

1. Thoroughly wash the machine using a pressure washer to remove all dirt, mud debris and residue.
2. Inspect the blade and rotor for damage or entangled material. Repair or replace damaged parts. Remove all entangled material.
3. Lubricate all grease nipples. Make sure that all grease cavities have been filled with grease to remove any water residue from the inside.
4. Touch up all paint nicks and scratches to prevent rusting.
5. Move to storage area.
6. Select an area that is dry, level and free of debris.
7. Unhook from tractor (see Section 2.4).
8. If the machine cannot be placed inside, cover with a waterproof tarpaulin and tie securely in place.

Store the machine in an area away from human activity. Do not allow children to play on or around the stored machine.

3.4 Trouble Shooting

This Finishing mower is designed to cut grass or other plants. It is a simple and reliable system that requires minimal maintenance.

In the following section, we have listed many of the problems, causes and solutions to the problems that you may encounter.

Problem & Possible Cause	Solution
Fishing mower doesn't turn Tractor clutch. PTO shaft Slips	Repair tractor PTO clutch Tighten or replace slip clutch.
Poor cutting job Traveling too fast. Blades dull. Grooves in grass. Scalping. Grass being left.	Slow down. Sharpen blades. Bent blade. Straight or replace blade. Machine too low. Raise machine. Top link too short. Extend top link.
Gearbox seal leaking Grease overheating.	Drill 3/16" hole in oil fill plug and insert cotter pin. Hole will act as a breather and prevent pressuring.
Vibration Out of balance.	Check for bent, damaged or broken blades. Repair or replace as required.

PARTS LIST

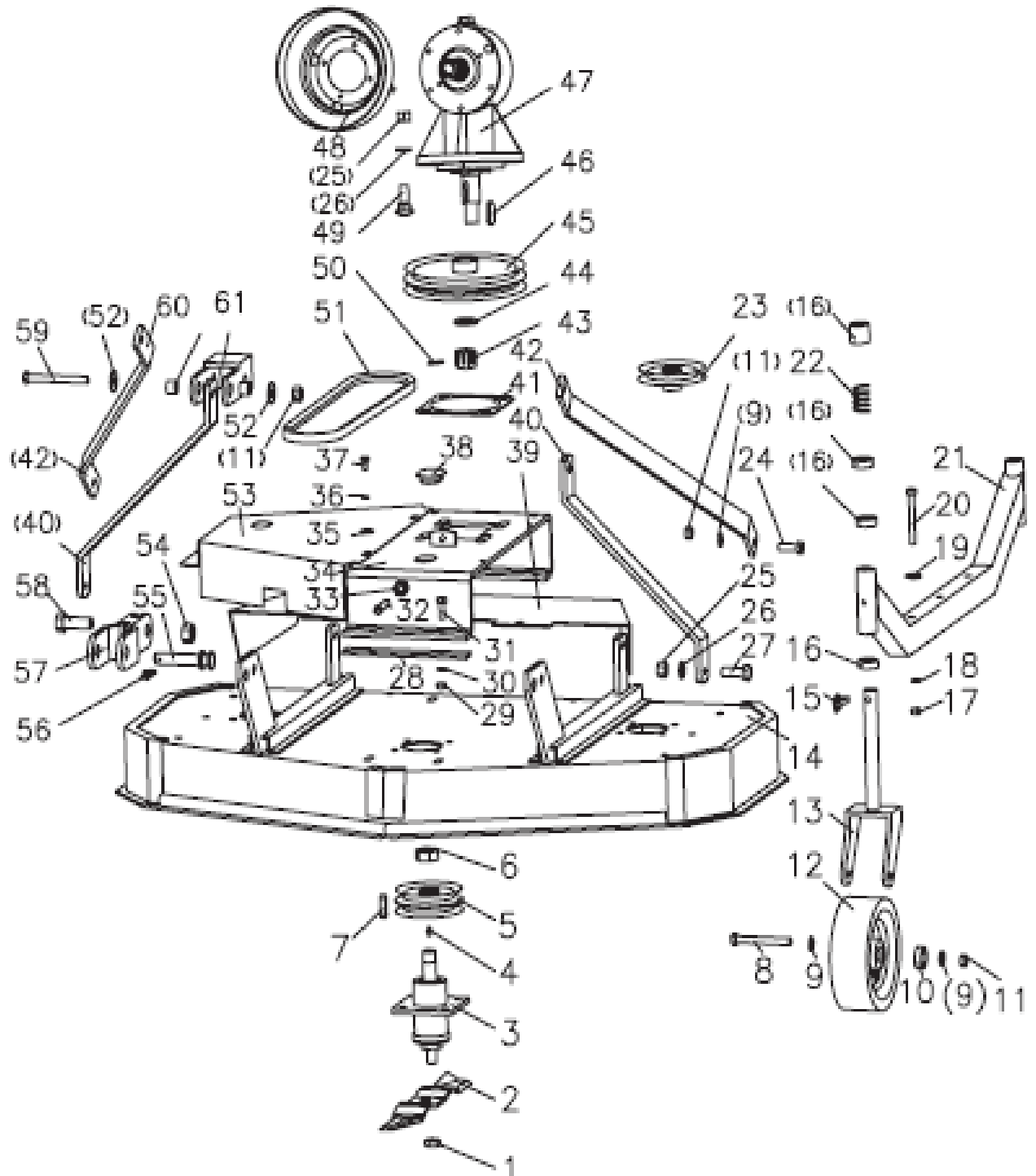

PARTS LIST

No	Part NO.	Name & Specifications	Qty
1	GB 6184-86	Locknut M18	3
2	FM120.00.118	Blade	3
	FM150.00.118	Blade	3
	FM180.00.118	Blade	3
3	FM120.00.016	Blade seat	3
4	GB 1152-89	Grease nipple M16	7
5	FM120.00.014	Belt wheel with double groove	1
6	GB 6184-86	Lock nut M24x1.5	3
7	GB 1096-86	Key A8x28	3
8	GB 5783-86	Bolt M12x110	4
9	GB 97.1-85	Plain washer 12	10
10	FM120.00.014	Nylon sleeve	8
11	GB 6184-86	Lock nut M12	7
12	FM120.00.018	Wheel Assembly	4
13	FM120.00.011	Wheel fork	4
14	FM120.00.019	Deck	1
	FM120.00.019	Deck	1
	FM120.00.019	Deck	1
15	200.56.011	Lock pin	4
16	FM120.00.115	Adjusting ring	4
17	GB 6170-86	Nut M10	6
18	GB 93-87	Spring washer 10	6
19	GB 96-85	Enlarged washer 10	11
20	GB 5782-86	Bolt M10x90	6
21	FM120.00.015	Wheel bracket	2
	FM120.00.015	Wheel bracket	2
	FM120.00.015	Wheel bracket	2
22	FM120.00.125	Spring	4
23	FM120.00.103	Belt wheel with single	2
24	GB 5783-86	Bolt M12x40	2
25	GB 6184-86	Lock nut M16	4
26	GB 97.1-85	Plain washer 16	4
27	GB 5783-86	Bolt M16x45	2
28	FM120.00.167	Plate	2
29	GB 6184-86	Lock nut M10	21
30	GB 97.1-85	Plain washer 10	16
31	GB 5783-86	Bolt M10x30	21
32	GB 85-88	Bolt M12x60	1
33	GB 6170-86	Nut M12	1
34	FM120.00.021	Gearbox seat	1
35	GB 96-85	Enlarged washer 8	4
36	GB 93-87	Spring washer 8	8

PARTS LIST

No.	Part NO.	Name & Specifications	Qty
37	GB 5783-86	Bolt M8x16	8
38	FM120.00.110	Rubber cover	3
39	FM120.00.106	Protecting plate	1
	FM150.00.106	Protecting plate	1
	FM180.00.106	Protecting plate	1
40	FM120.00.113	Front link rod	2
	FM150.00.113	Front link rod	2
	FM180.00.113	Front link rod	2
41	FM120.00.108	Gasket	1
42	FM120.00.109	Rear link rod	2
	FM150.00.109	Rear link rod	2
	FM180.00.109	Rear link rod	2
43	GB 6178-86	Nut M24	1
44	GB 97.1-85	Plain washer 24	1
45	FM120.00.012	Belt wheel (large)	1
46	GB 1096-86	Key A10x45	1
47	XH30.283Z.01L	Gearbox assembly	1
48	FM120.00.199	Cover	1
49	GB/T 12-88	Bolt M16x45	4
50	GB 91-86	Splint pin 4x45	1
51	GB/T 11544-97	Belt (B) 1549	2
	GB/T 11544-97	Belt (B) 1753	2
	GB/T 11544-97	Belt (B) 1930	2
52	GB 96-85	Enlarged washer 12	2
53	FM120.00.121	Cover for belt wheel	2
	FM150.00.121	Cover for belt wheel	2
	FM180.00.121	Cover for belt wheel	2
54	GB 6184-86	Lock nut M20	2
55	ZL-25.105	Pin	3
56		R pin	3
57	FM180.00.017	Lower link bracket	2
58	GB 5783-86	Bolt M20x55	2
59	GB 5782-86	Bolt M 12X90	1
60	FM180.00.111	Sleeve	2
61	FM180.00.112	Upper link bracket	1

PARTS LIST

Wheel Assembly

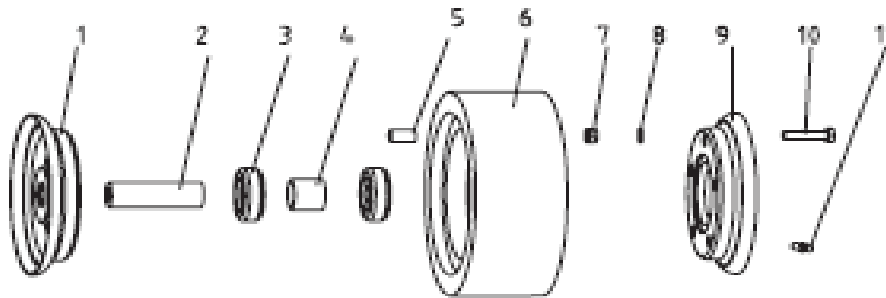

No.	Part NO.	Name & Specifications	Qty
1	FM120.00.161a	Steel rim (a)	1
2	FM120.00.166	Bushing	1
3	GB 279-88	Bearing 160205	2
4	FM120.00.165	Spacer	1
5	FM120.00.162	Bushing	5
6	FM120.00.164	Rubber wheel	1
7	GB 6184-86	Lock nut M8	5
8	GB 97.1-85	Plain washer 8	5
9	FM120.00.161	Steel rim	1
10	GB 5783-86	Bolt M8x35	5
11	GB 1152-89	Grease nipple M16	1